

# Technique for controlling Agilent External DC Power Supply from SMU to expand SMU output power capability

## Technical Overview

- Maximum 500 W Output
  - 50 A / 8 V (Agilent 6651A)
  - 25 A / 20 V (Agilent 6652A)
  - 10 A / 50 V (Agilent 6654A-J05)
- Fast measurement speed
- Accurate Measurement for high power devices

## Introduction

High power devices up to 500W can be measured precisely with an SMU if combined with the

external DC power supply and the SMU of the Agilent E5270B Series Precision Measurement Solutions or Agilent

4155C/4156C Semiconductor Parameter Analyzers.

The Agilent 654X/664X/655X/665X series performance DC Power Supply (P.S) shown in Figure 1 is suitable for combining with the SMU for high power semiconductor applications. The maximum power available from this power supply is 500 W, and it provides both the accuracy and speed required in high power device measurements. The fast current force and sink capability of these power supplies ensure a fast response when combined with the SMU.

## Agilent E5270B Series Precision Measurement Solutions



Agilent E5270B 8 slot Precision Measurement Mainframe with 4 HRSMU and 2 HPSMU plug-in modules

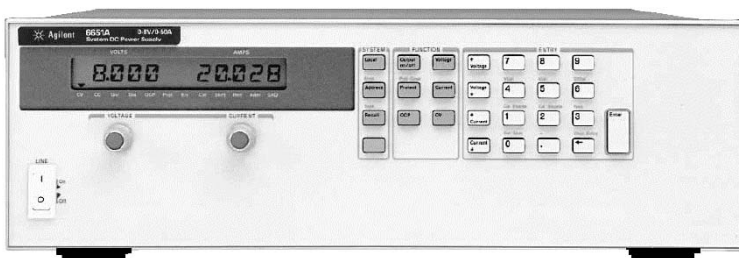

Figure 1. Agilent 6651A Performance DC Power Supply

These DC power supply series have a modulation input for analog programming, and the output voltage can be controlled from the SMU by using the modulation input. The current output from the power supply can be also measured using the analog current monitor output of the power supply.

However the design of the analog control of these power supply series does not support direct connection of the SMU to the analog input. To control the power supply from the

SMU, a simple CR circuitry must be added in series to the analog control input of the power supply; an ideal solution.

The following two issues have to be solved:

1. The analog control signal of the power supply requires a floating signal:  
SMU output is grounded at one end, and therefore the SMU output needs to be converted to floating when viewed from the power supply.
2. The power supply oscillates if the SMU is simply connected to the power supply:  
The polarity of the control input signal is designed in the inverse direction when controlled from the SMU; this creates a positive feedback loop, resulting in unstable power supply operation if the SMU output is connected

directly to the analog input of the power supply.

These technical issues can be easily solved by adding a simple CR circuitry in series to the analog input of the power supply.

This technical note provides information on how to interface with these external power supplies to take advantage of the attractive features introduced; also, it explains the theory of operation to back up the implementation.

## Theory of operation

### 1. Positive Voltage Output

The output of the power supply is single polarity and can only be made for positive voltage or negative voltage depending on the power supply connection to the DUT. The connection of analog control from the SMU also differs for positive or

negative output connection to the power supply.

First, the technique for connecting positive voltage output is shown.

### Setting output voltage

The basic connection diagram of the SMU, external power supply and the device under test (DUT) is shown in Figure 2.

The drain and the source of the DUT are connected to the external power supply using four terminal Kelvin methods to prevent the voltage drop caused by the resistance of the connection wire and the contact resistance to the DUT.

The GNDU is connected to the source terminal of the DUT as the reference point of the measurements. A protection fuse is inserted between the source and the GNDU connection. The fuse is used for protecting the GNDU from any damage when accidental abnormal high power flows into the GNDU.

SMU3 controls the output voltage of the power supply and SMU1 and SMU2 monitor the current output of the power supply. SMU4 supplies the gate voltage to the DUT.

If the current flowing into the GNDU is small, as in the example, or the voltage drop by the source and the GNDU connection is negligibly small, then the source can be connected to the circuit common instead of the GNDU as shown in Figure 3.

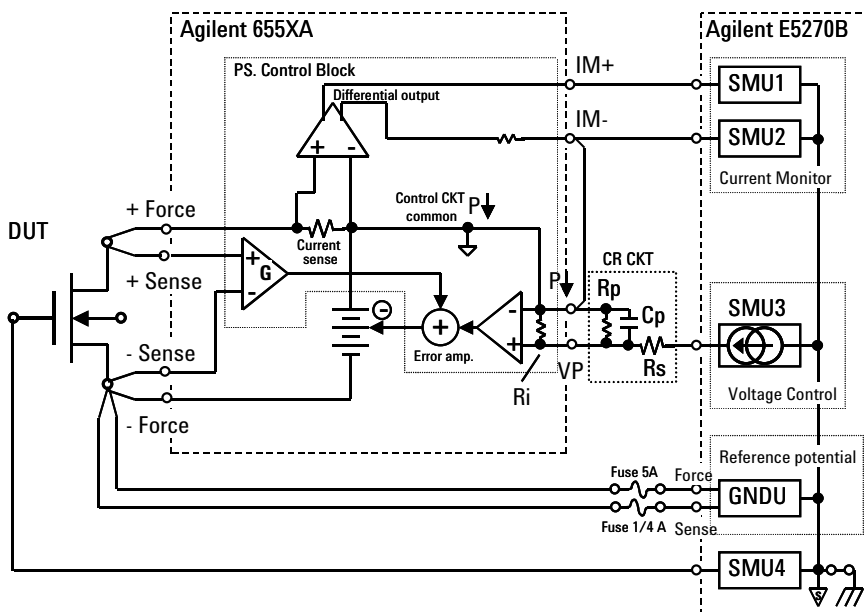

Figure 2. Connection block diagram for +Vo output

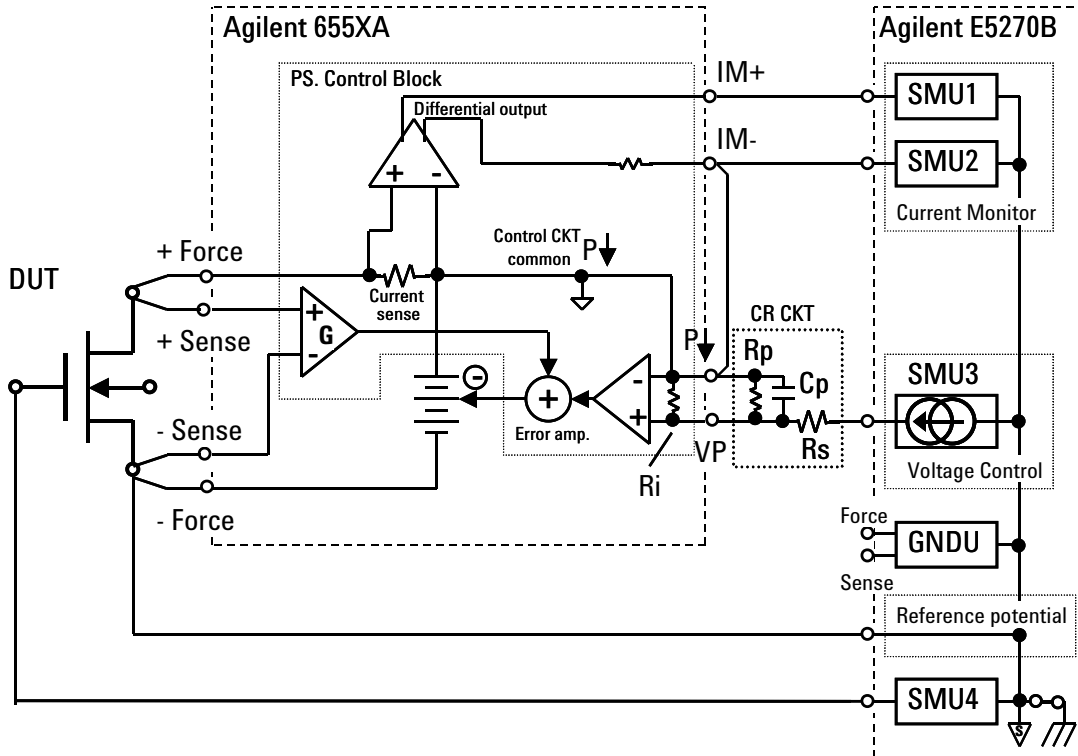

Figure 3. Connection block diagram for +Vo output for easy connection

### Feedback loop using SMU voltage force

Figure 4 shows the feedback loop in the voltage force mode of the power supply when the output voltage is controlled by using the voltage mode SMU. Two loops are shown, one for controlling voltage  $V_c$  from the SMU and the other for the internal voltage control source  $V_p$ .  $V_p$  represents the voltage set by the front panel voltage knob or DAC voltage that is set over the GPIB input to the power supply.

In short, the relation between the output voltage  $V_o$ , SMU control voltage  $V_c$  and the internal voltage source  $V_p$  is expressed in the following equation:

$$V_o = (-V_p - k * V_c) / ((G - k) * (1 - A*k/(G-k))) \quad (1)$$

Where

$V_o$  : Output voltage

$V_p$  : P.S internal voltage for setting the output voltage

$k$ : Voltage division ratio by the  $R_s$ ,  $R_p$  and  $R_i$  resistor

$$k = R_i * R_p / (R_i * R_p + R_s * (R_i + R_p)) \quad (2)$$

$V_c$  : SMU output  $V$

$V_{oc}$  : Internal voltage drop between the control circuit common and the "+ Sense terminal"

$A = V_{oc}/V_o$  ; the ratio of plus side internal voltage drop and the output voltage

$G$  : Gain of the voltage sense amplifier of the power supply or equivalent to the power amplifier's gain ( $=1/G$ )

To make the equation simple,  $A$  is set to a typical case,  $A=0$ .

Then equation (1) can be re-written as follows:

$$V_o = (-V_p - k * V_c) / (G - k) \quad (3)$$

Equation (3) indicates that the loop becomes unstable if  $k \geq G$ .

Therefore  $k$  must be smaller than  $G$  to keep the power supply stable.

If we set  $k = G/2$  with a certain margin for the unstable condition, then equation (3) becomes the next equation:

$$V_o = -2 * V_p/G - V_c \quad (4)$$

Where  $V_p = 0$  when the output is controlled from the analog input.

This equation suggests the SMU control voltage  $V_c$  is the same magnitude as the output

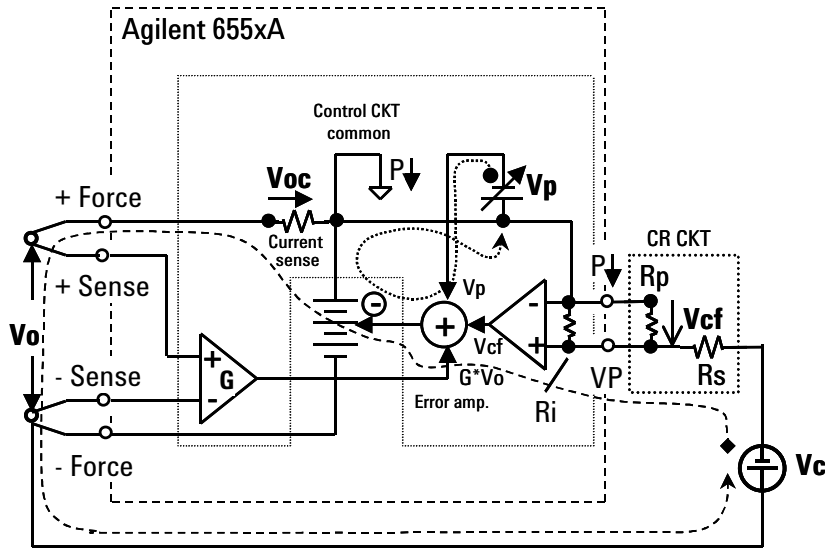

Figure 4. Feedback control loop for +Vo output controlled using SMU V force mode

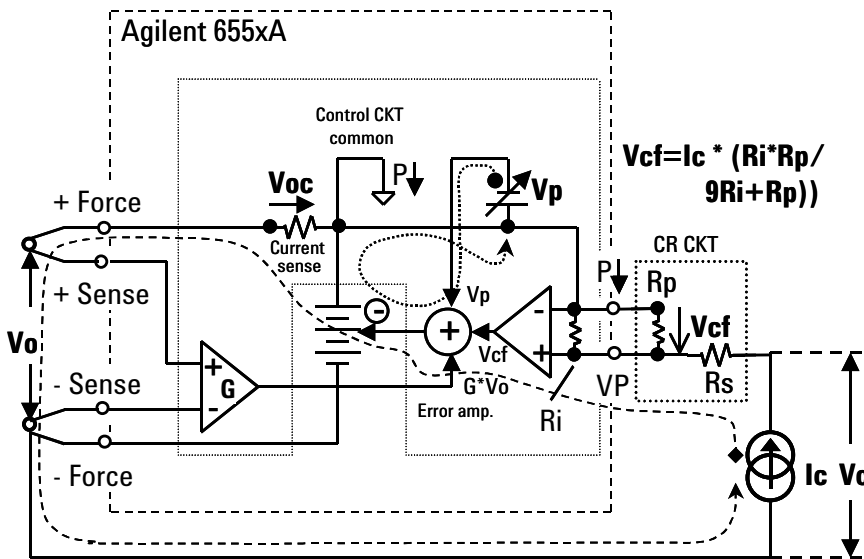

Figure 5. Feedback control loop for +Vo output controlled using SMU I force mode

voltage  $V_o$ , but the opposite polarity. The sensitivity of  $V_p$  for  $V_o$  doubles, but it does not matter because  $V_p$  is usually zero in the application. Setting the  $K$  value to about  $G/2$  is a good choice considering (1) the magnitude of the output voltage of the SMU and the power supply becomes about the same and (2) the stability of the system.

In the later section,  $K$  is assumed to be  $K = G/2$ .

Returning to equation (1), let's check another case where  $A$  is not zero. Equation (1) suggests the system also becomes unstable if the other denominator term  $(1 - A*k/(G-k))$  becomes zero or negative.

If we set  $K=G/2$ , the denominator can be rewritten as  $(1-A)$ ; and the power supply becomes unstable when the internal voltage drop at the positive output terminal becomes the same voltage of the power supply output  $V_o$  or larger. This condition is possibly seen, for example, in the ON resistance test of the power transistor. This condition can be avoided by, for example, reducing the force line resistance, limiting the minimum load resistance or by using the control methods shown in the next paragraph.

### Feedback loop using the SMU current force

As shown in the previous paragraph, there still remain some cases where the power supply control loop may become unstable when the load resistance is very small.

If we drive the power supply using the current source mode of the SMU as shown in Figure 5, then the  $k$  factor in the equation (1) becomes zero because  $R_s$  in the equation (2) can be considered infinite since the output impedance of the current source mode SMU connected in series to  $R_s$  is infinite.

If we use the current source SMU to drive the power supply, then equation (1) can be re-written by adding the  $V_{cf}$  term that is a replacement of  $V_c$  when using the current source SMU:

$$V_o = -V_p / G - V_{cf} / G \quad (5)$$

Where

$V_{cf} = I_c * (R_i * R_p / (R_i + R_p))$ ;  $V_{cf}$  is generated by the current source ( $I_c$ ) from the SMU and

$I_c$  is converted to a voltage by the input resistor consisting of  $R_i$  and  $R_p$ .

$$G = 5V / \text{Maximum output voltage specified by the power supply } [=V_o (\text{max})]$$

where 5 V is the analog control input voltage to output the rated maximum voltage of the power supply.

Therefore the relation between the current source  $I_c$  and the power supply output voltage is expressed by the following equation:

$$I_c = - V_o * (5 / (V_o (\text{max}))) * ((R_i + R_p) / R_i * R_p) \quad (6)$$

The voltage compliance required for full-scale voltage output is expressed as:

$$V_c (\text{max}) = V_o (\text{max}) + (R_i * R_p / (R_i + R_p) + R_s) * I_c (\text{max})$$

$$= V_o (\text{max}) - 5 * (1 + R_s * (R_i + R_p) / R_i * R_p)$$

Under the condition  $K=G/2$  and  $G=5/V_o (\text{max})$  as discussed, the equation can be written using equation (2):

$$V_c (\text{max}) = V_o (\text{max}) - 5 * (2/5) * V_o (\text{max}) = -V_o (\text{max})$$

This equation means the voltage compliance of the SMU in current force mode has to be set larger than the maximum output voltage of the power supply and the polarity is the opposite direction of the full output voltage of the power supply.

### Frequency compensation

The analog control signal of the power supply is expected to use a floating signal source, which can be realized by using a current source of the SMU as described.

The output resistance of the current source of the SMU can be considered infinite in low frequencies, but the resistance gradually lowers as the frequency rises and eventually it behaves the same as the voltage source at a certain point of high frequency. As explained, in very severe operating conditions, the system may become unstable, and it may show unwanted transient output from the power supply.

To overcome this potential issue, a capacitor  $C_p$  is added in the CR circuit as shown in Figure 2. By adding an appropriate capacitor as shown in Figure 2, the current source mode SMU is seen as an ideal floating signal source in all the frequency range.

The -3 db cutoff frequency of the CR circuit should be set around a few kHz to take account of the frequency response of the power supply and the SMU. The cutoff frequency is calculated by the following equation:  $f (-3\text{db})$

$$= 1 / (2 * \text{pai} * C * R). \text{ For example, if } C=0.1 \mu\text{F} \text{ is chosen and } R=1 \text{ kohm, then } f (-3 \text{ db}) = 1.6 \text{ kHz, which satisfies the required condition.}$$

### Current Monitoring

The analog signal of the current output of the power supply is provided in these power supply series.

The full-scale output of the current monitor is five volts and it is on the plus output voltage side of the power supply. The current output from the power supply can be measured by reading the analog monitor output by using a differential voltage measurement technique.

## 2. Negative Voltage Output

The connection of the power supply and the SMU for negative voltage output is introduced.

### Connection block diagram and feedback loop

Figure 6 is the connection

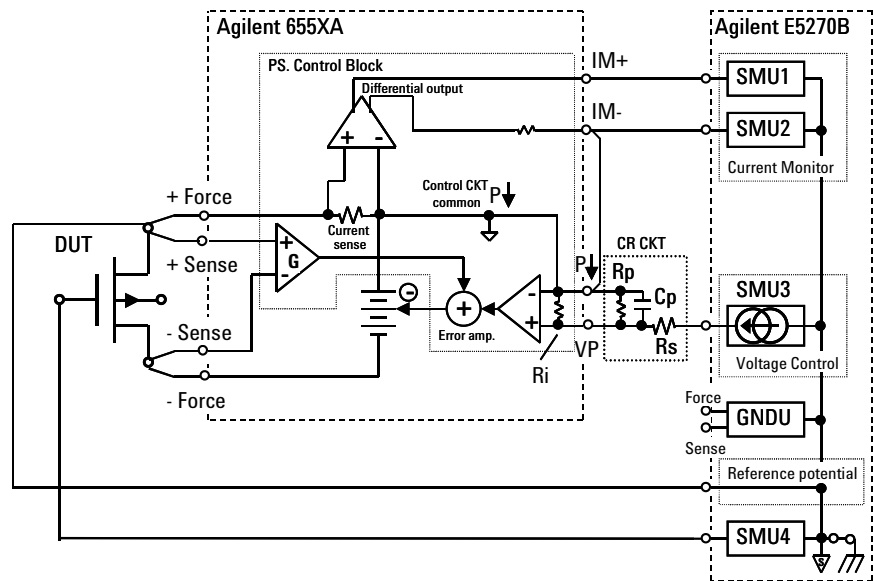

Figure 6. Connection block diagram for  $-V_o$  output

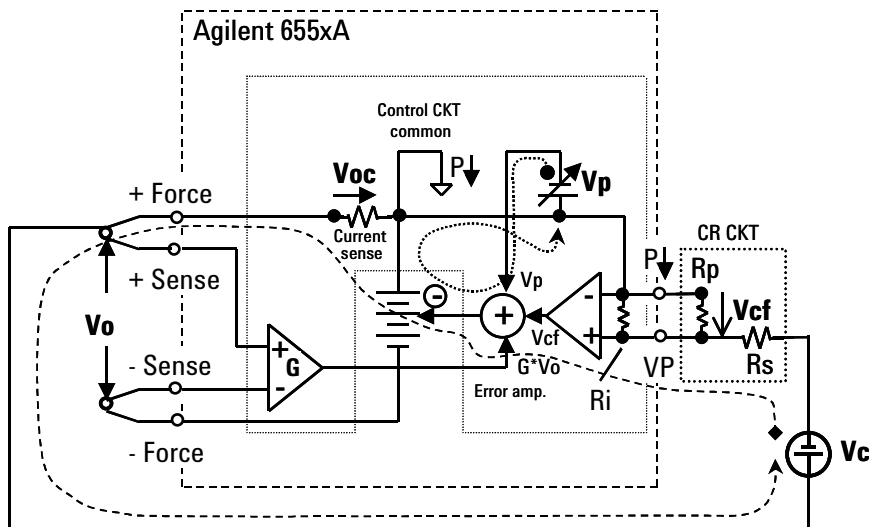

Figure 7. Feedback control loop for -Vo output controlled using SMU V force mode

block diagram for negative voltage output.

The basic idea and the theory of the control is the same as the positive voltage output case except for the difference in the connection to the DUT and the SMU.

Figure 7 shows the feedback loop for negative voltage output. It uses a voltage source SMU for the purpose of worst-case analysis.

The equivalent for equation (1) can be written as follows in the case of negative voltage output.

$$V_o = (-V_p - k * V_c) / (1 - A*k/G)/G \quad (7)$$

Equation (7) shows that  $A*k/G=1$  is the unstable condition.

We set  $K=G/2$  to be the same as the positive output case, and  $A=2$  becomes the condition where the system becomes unstable. This is the condition when the voltage drop in the internal +Force output becomes more than twice the power supply output  $V_o$ . Since the unstable condition in the

positive output is at  $A=1$ , the negative voltage output is more stable than the positive output.

Using a current source mode for controlling the power supply, just as in the positive output case, equation (7) can be rewritten as the next equation, which is the same equation (5) that is derived for positive output:

$$V_o = -V_p / G - V_{cf} / G \quad (5)$$

The voltage compliance required for the SMU is expressed by the following equation:

$$V_c (\max) = -2 * V_o (\max)$$

The voltage compliance of the SMU in the negative voltage output must be set to at least twice the power supply output voltage, which is twice the positive output case.

Note: If you want to reduce the SMU compliance in the same way as the positive output (i.e.  $V_c (\max) = -V_o (\max)$ ), then the  $k$  factor (voltage divider of CR CKT) needs to be halved. However using the same  $k$

factor, i.e. the same CR divider circuit, would be easier for maintaining the system.

## Typical CR Value and Parameter Conversion Factor

The following parameters are shown in Table 1 for the positive voltage output connection, and in Table 2 for the negative voltage setting.

- **Output voltage and current range of power supply**
- **Recommended CR circuit value**
- **Current forth factor for one-volt output from power supply**
- **Ratio of SMU output voltage and power supply output voltage**

The current force value is calculated by multiplying the factor to the intended power supply output voltage. For example, to output 10 V using the 6642A P.S, then 0.00275 A (=10 V x -0.0002750 A/V) is forced from the SMU to the analog input through the CR circuit.

You can figure out the rough SMU voltage for controlling the power supply by multiplying the factor by the power supply output voltage; then you can set the minimum voltage compliance for the SMU using this value. Note that the actual voltage required for the SMU becomes slightly higher than the calculated value to compensate the voltage drop of the force line of the power supply.

For example, to output 10 V using the 6642A P.S, the calculated value is -11.228 V

(=10 V x -1.1228 V/V), but a value greater than -15 V is advisable.

- **Conversion factor from current monitor voltage to**

**power supply current reading**

The current output from the power supply is calculated by multiplying the factor by the

monitored voltage.

You may need to compensate the reading by using the front panel current reading because the analog current

Agilent Power Supply Model	Rp	Rs	I Force (SMU) / P.S V Output	V Force (SMU) / P.S V Output	P.S Max. Output V	P.S I Output (A) / P.S I Monitor (V)
6641A/6541A 8V-20A	1000	2150	-0.0006875	-1.1031	8	-4.0000
6642A/6542A 20V-10A	1000	6810	-0.0002750	-1.1228	20	-2.0000
6643A/6543A 35V-6A	1000	12100	-0.0001571	-1.0443	35	-1.2000
6644A/6554A 60V-3.5A	1000	21500	-0.0000917	-1.0542	60	-0.7000
6645A/6545A 120V-1.5A	1000	46400	-0.0000458	-1.1683	85 * <sup>1</sup>	-0.3000
6651A/6551A 8V-50A	1000	2150	-0.0006875	-1.1031	8	-10.0000
6652A/6552A 20V-25A	1000	6810	-0.0002750	-1.1228	20	-5.0000
6653A/6553A 35V-15A	1000	12100	-0.0001571	-1.0443	35	-3.0000
6554A/6654A-J05 50V-10A	1000	19600	-0.0001100	-1.2560	50	-2.0000
6654A/6554A 60V-9A	1000	21500	-0.0000917	-1.0542	60	-1.8000
6655A/6555A 120V-4A	1000	46400	-0.0000458	-1.1683	85 * <sup>1</sup>	-0.8000

Note: Other parameters : Ri = 10 kohm (Input R), Cp = 0.1 uF. \*1: Maximum output is limited to this voltage.

Table 1. Table for positive voltage output: CR circuit value and conversion factor for SMU to control power supply and to read back current from power supply.

Agilent Power Supply Model	Rp	Rs	I Force (SMU) / P.S V Output* <sup>1</sup>	V Force (SMU) / P.S V Output* <sup>1</sup>	P.S Max. Output V	P.S I Output (A) / P.S I Monitor (V)
6641A/6541A 8V-20A	1000	2150	-0.0006875	-2.1031	- 8	4.0000
6642A/6542A 20V-10A	1000	6810	-0.0002750	-2.1228	- 20	2.0000
6643A/6543A 35V-6A	1000	12100	-0.0001571	-2.0443	- 35	1.2000
6644A/6554A 60V-3.5A	1000	21500	-0.0000917	-2.0542	- 60	0.7000
6645A/6545A 120V-1.5A	1000	46400	-0.0000458	-2.1683	- 85* <sup>2</sup>	0.3000
6651A/6551A 8V-50A	1000	2150	-0.0006875	-2.1031	- 8	10.0000
6652A/6552A 20V-25A	1000	6810	-0.0002750	-2.1228	- 20	5.0000
6653A/6553A 35V-15A	1000	12100	-0.0001571	-2.0443	- 35	3.0000
6554A/6654A-J05 50V-10A	1000	19600	-0.0001100	-2.2560	- 44* <sup>2</sup>	2.0000
6654A/6554A 60V-9A	1000	21500	-0.0000917	-2.0542	- 48* <sup>2</sup>	1.8000
6655A/6555A 120V-4A	1000	46400	-0.0000458	-2.1683	- 45* <sup>2</sup>	0.8000

\*1: The control signal polarity of the SMU to control the power supply is the same as the case for positive output. The polarity of the power supply output is referenced to the negative output terminal.

\*2: Maximum output is limited to this voltage.

Table 2. Table for negative voltage output: CR circuit value and conversion factor for SMU to control power supply and to read back current from power supply

monitor output is not calibrated precisely. For example, if the voltage reading for IM from the 6642A is -2.5 V, then the actual current output from the 6642A is 5 A (= -2.5 V x -2.0 A/V).

## Accuracy

The following two items regarding to the measurement accuracy need to be considered when combining the SMU and the external power supply.

- Voltage set accuracy
- Current measurement accuracy

These two points are discussed below.

### Voltage force accuracy

There are three parameters that determine the voltage set accuracy in this configuration: Analog programming (VP) accuracy of the power supply, divider CR circuit accuracy and the current force SMU accuracy.

The sum of these three accuracy parameters can be thought of as the maximum error of the combined system.

For example, supposing the Agilent 6653A 35 V 15 A power supply is used as the external power supply, the accuracy of the three parameters will be:

- Analog programming (VP) accuracy: 0.36% of setting + 27 mV (or 0.08% of f.s).
- Divider CR circuit accuracy: Maximum 2% for 1% resistor,

but can be less than 0.5% in typical cases because the actual resistor accuracy is much better than the specification.

- SMU accuracy: 0.12% of setting + 4 uA (or 0.08% of

programming SMU f.s - 5mA) in 10mA current range (max current is about 5 mA in the example)

Then the maximum voltage set error is calculated as:

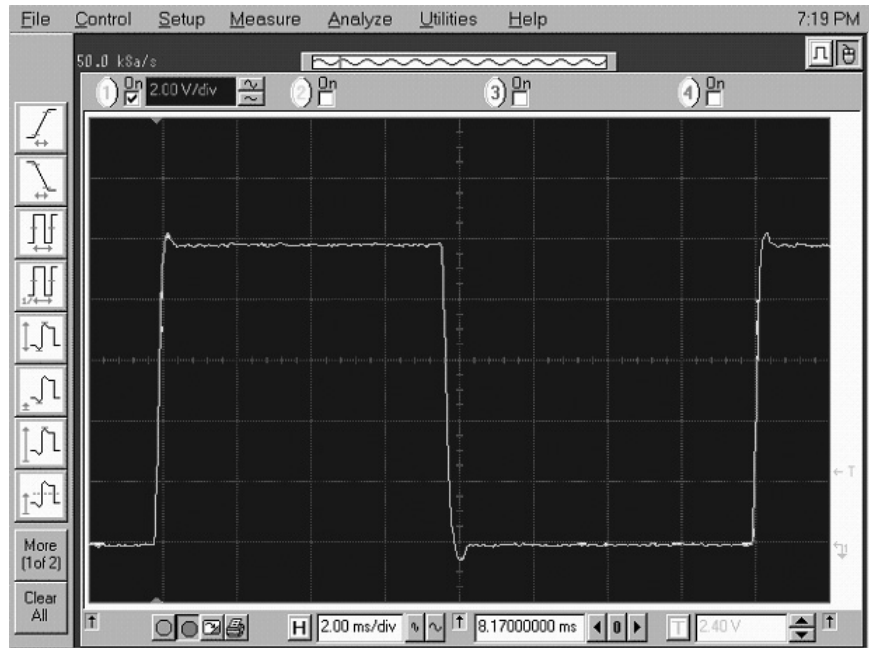

Figure 8. Transient response of power supply at 10 V - 4 A voltage swing

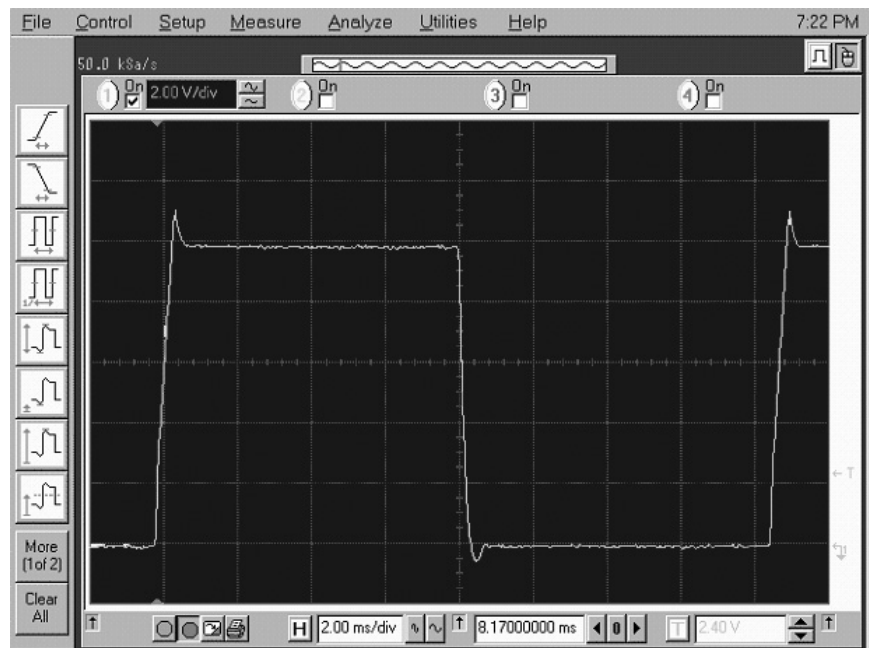

Figure 9. Transient response of power supply at 10 V - 9 A voltage swing



$(0.36 + 2 + 0.12)\%$  of setting +  $(27 + 35 \text{ V} * 1000 * 4 \text{ u} / 5 \text{ m}) \text{ mV}$   
 $= 2.48\%$  of setting +  $55 \text{ mV}$

Since most of the error comes from the accuracy of the divider CR circuit, the error can be reduced easily by calibrating the total gain in the control parameter by referencing the output voltage readout of the power supply.

The voltage read-back accuracy of the power supply in the front display is as follows:

$0.07\%$  of reading +  $25 \text{ mV}$  (or  $0.07\%$  of f.s).

By referencing the voltage readout of the power supply, the total accuracy in the voltage set can be reduced from  $2.48\%$  to  $0.07\%$  by multiplying the calibration factor (= voltage set parameter/power supply read-back voltage) when setting the voltage.

### Current measurement accuracy

The accuracy of the analog current monitor is not calibrated. The accuracy depends on the raw resistance value that is used for detecting the current. The accuracy of the "+I mon" output in the Agilent 6653A, for example, is:

$7\%$  of reading +  $120 \text{ mA}$  (or  $0.8\%$  of f.s).

This can be also calibrated using the current read-back in the front panel display of the power supply. The accuracy of the current read-back is:

$0.15\%$  of reading +  $15 \text{ mA}$  (or  $0.1\%$  of f.s).

The base data of the read-back current is the same source of the analog monitor; the analog

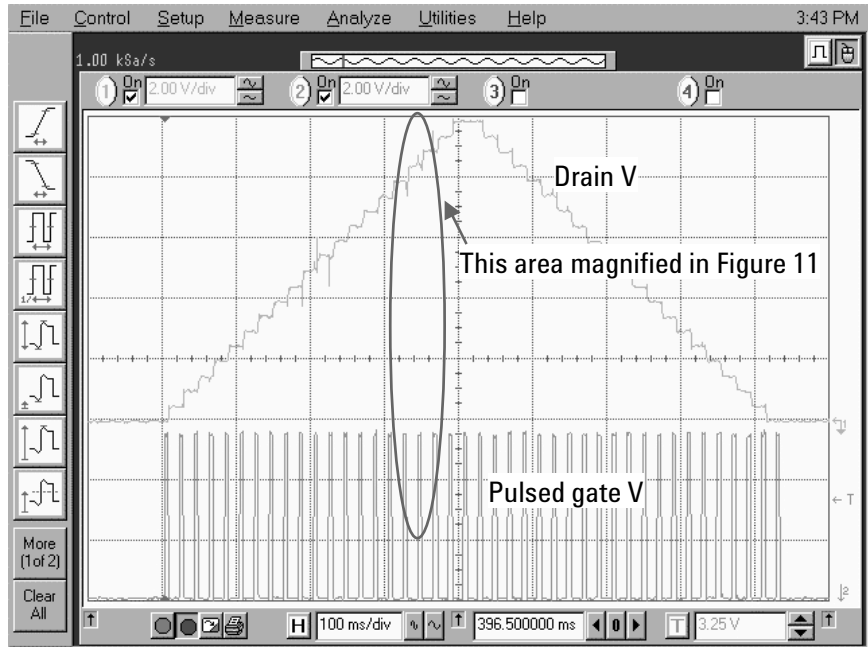

Figure 10. Pulsed double sweep measurements ( $I_d > 8 \text{ A}$  at  $V_d > 6 \text{ V}$ )

monitor accuracy becomes the same as the current read-back accuracy by calibrating the gain and the offset.

The voltage measurement accuracy of the SMU of the Agilent E5270B is  $0.03\%$  of reading +  $4 \text{ mV}$  (or  $0.03\%$  of  $5 \text{ V}$  that is current f.s voltage) in  $20 \text{ V}$  range, and can be ignored because it is negligible compared with the readout accuracy of the power supply.

## Performance

### Response time & Kelvin connection

The response time or response speed of the power supply directly affects the performance in measurement accuracy and the measurement throughput.

Figures 8 and 9 show the waveform when the power supply swings  $10 \text{ volts}$  driven by the SMU. The current load is  $4 \text{ A}$  in Figure 8 and shows a

good transient response with a small overshoot in the rising and falling edges. Figure 9 shows the case at  $9 \text{ A}$  current load; it shows a slightly larger spike compared with the  $4 \text{ A}$  case, but the settling to the final voltage is quick and stable without any ringing. A part of the rise time depends on the SMU slew rate and the CR time constant added in series to the analog control input of the power supply.

Figure 10 shows the voltage waveform of double sweep measurements of drain and a pulsed gate voltage. The circled portion of the waveform is enlarged in Figure 11. Since the drain current is off when the gate pulse is zero volts and flows about eight amperes in the example when the gate pulse is on status. As can be seen from Figure 11 in the two circles, there is no dip in the drain voltage when the drain current is switched from zero amperes (in the smaller circle) to eight amperes (in the larger

circle) because the Kelvin connection works properly even for high current switching in a short period of time. If the Kelvin connection is not made, then the drain voltage will drop as shown by the dotted dip in the larger circle.

Figure 12 shows the voltage dip under non-Kelvin connection as an example waveform. Since the voltage dip is about two volts under eight amperes current difference, the force line resistance is about 0.25 ohm ( $= 2 \text{ v} / 8 \text{ A}$ ). Since this

range of small resistance easily exists in the force line connection, Kelvin connection of fast response is very important in high current applications.

Overall, these examples show the feedback loop for keeping the Kelvin connection very stable; you can obtain fast and accurate measurements by using the proposed combination with the external power supply and SMU.

### Preventing heat-up

In high power measurements, reducing the heat-up of devices is important for accurate characterization for model parameter extraction or comparing device characteristics.

Figure 13 shows an example of the effect of device heat-up. The measurements are performed using double sweep for drain voltage by changing the gate bias voltage as a secondary sweep. The top of the sweep is about nine amperes at drain current and maximum drain voltage is swept to ten volts. While the sweep is made from zero to ten volts, the device is heated-up and the drain characteristics show different curves when swept back from ten volts as indicated by the two arrows.

Figure 14 shows the result in faster measurements of about 0.8 seconds in one double sweep for 42-point measurements or about 20 ms per sweep point. The difference in the two sweep directions becomes smaller than in the example in Figure 13 and even the example in Figure 14 is swept to higher

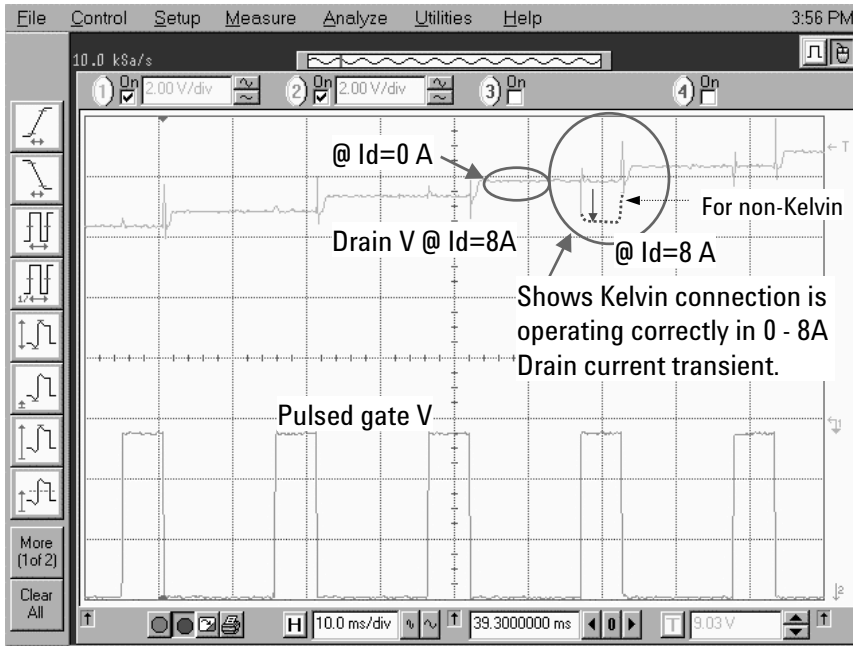

Figure 11. Enlarged pulsed double sweep

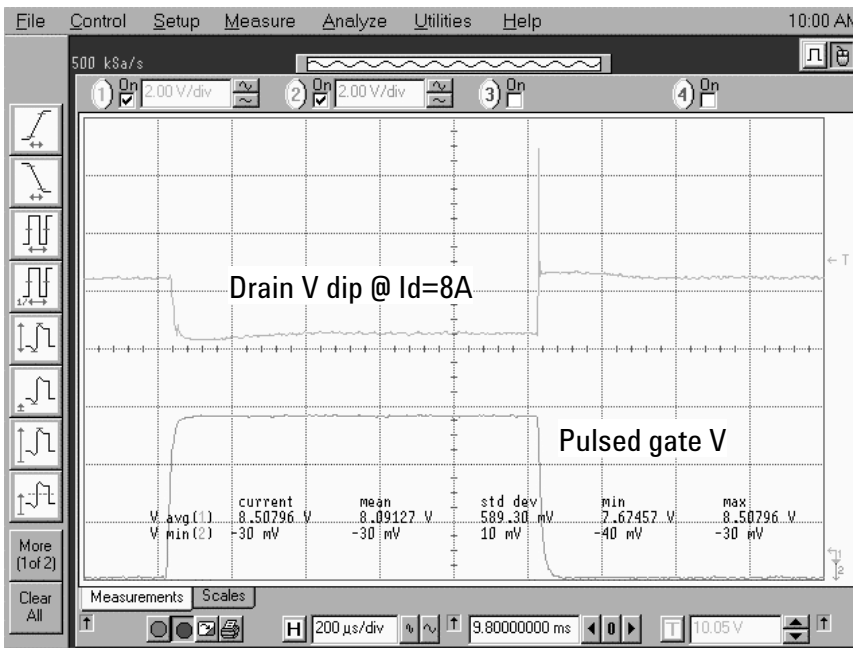

Figure 12. Example of voltage dip at device under non-Kelvin connection

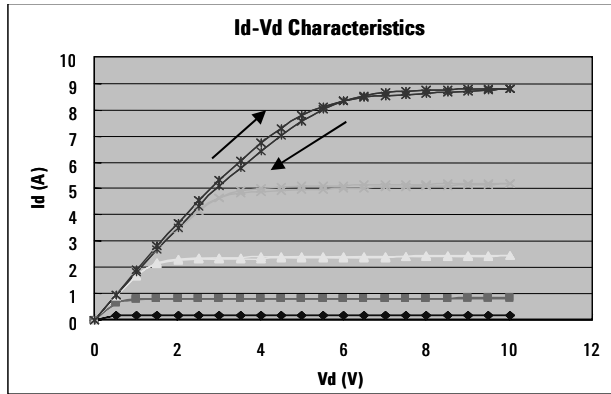

Figure 13. Double sweep example during slow speed measurements

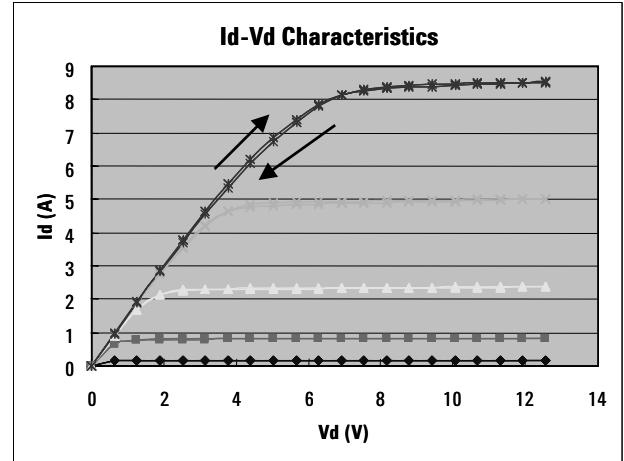

Figure 14. Double sweep example during fast measurements

voltage/power (10 V in Figure 13 and 12.5 V in Figure 14).

Figure 15 shows an example of the pulsed measurements with the pulse applied to the gate and the average power consumed by the DUT reduced. The pulse width is 10 ms and pulse duty is about 10%. There is no hysteresis curve seen in the measurements, and the pulsed measurements can be seen as an effective approach to reducing the parameter drift caused by device heat-up. The penalty of the pulsed measurements is the longer time for total measurements. In production use for monitoring device performance, faster measurement speed usually satisfies both the accuracy and throughput requirements.

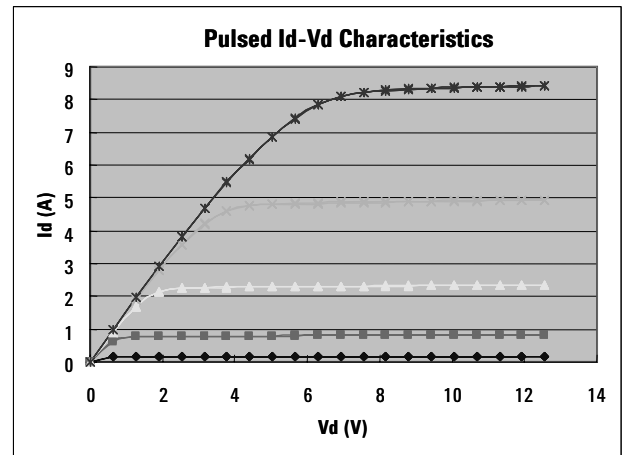

Figure 15. Pulsed double sweep example

## Hint for obtaining a better transient response

Low inductance wiring from the power supply to the DUT is one of the key techniques for achieving a better transient response at the DUT. Techniques such as twisting

+ Force and - Force lines together or laying two lines in parallel with minimum spacing are widely used to minimize the inductance of the force line wiring and to improve the transient response of the high power supply system. Such techniques are especially important when pulsed measurements are made.

## Conclusion

The basic idea of how to connect and control the Agilent 654X/664X/655X/665X series performance DC Power Supply to the SMU for increasing the equivalent SMU output power and the background theory for ensuring the stable operation is outlined.

The typical parameters for connecting the specific power supply with a different output range are shown in Tables 1 and 2 to facilitate implementation without calculation by the user.

The accuracy of setting the output voltage and reading the current can be calibrated to approach the accuracy specification of the power supply by using the front panel reading of the power

supply. Therefore, standard parts (two resistors and one capacitor) available in the market can be used for implementing this solution, and no special parts are required.

Finally the effectiveness of the Kelvin connection and a hint for eliminating the effects of heat-up of the DUT are described.

These examples are based on the Agilent E5270B 8 Slot Precision Measurement Mainframe and Agilent 6654A Performance DC Power Supply.

The actual application and the connection between the external power supply and SMU are shown in the following application notes:

For Agilent E5270B:  
Application Note E5270-6,  
Agilent publication number 5989-0921EN.

For Agilent 4155C/56C:  
Application Note 4156-5,  
Agilent publication number 5989-0922EN.

## Additional Information

For more information about Agilent Technologies parametric test products, please visit:  
[www.agilent.com/see/parametric](http://www.agilent.com/see/parametric)

## Contact Information

### Americas

Brazil (11) 4197-3600  
Canada (French) 1 877 894-4414  
Canada (English) 1 800 447-8378  
Mexico 33 134-5841  
United States 1 800 447-8378

### Asia/Asia Pacific

Australia 1 800 629-485  
China 1 800 276-3059  
Hong Kong 852 2599 7889  
India 91/11 690-6156  
Japan 0120 421-345  
Malaysia 1 800 880-780  
New Zealand 0 800 738 378  
Philippines 1 800 1651-0135  
Singapore 1 800 276-3059  
South Korea 080 778-0011  
Taiwan 0 800 047-662  
Thailand 1 800 2758-5822

### Europe

Austria (01) 25 125-7183  
Belgium (0) 2 404-9380  
Denmark 080301040  
Finland 20 547-9999  
France (0) 825 010710  
Germany (0) 18 05 24-63 34  
Greece 20 547-9999  
Ireland 016158393  
Italy 02 92 60 8333  
Luxembourg (0) 2 404-9340  
Netherlands (0) 20 547-9999  
Poland 20 547-9999  
Russia 20 547-9999  
Spain 91 631 3383  
Sweden 020 120-9975  
Switzerland (Italian) (0) 2 92 60 8484  
Switzerland (German) (0) 1 735-9300  
Switzerland (French) (0) 825 010 700  
United Kingdom (0) 7004 222-222

### Middle East

Israel 20 547-9999

Technical data subject to change without notice.

Microsoft Windows is the registered trademark of Microsoft Corporation.

© Copyright 2006 Agilent Technologies  
Printed in USA Aug 1, 2006

5989-0920EN